

AQUA LUXES

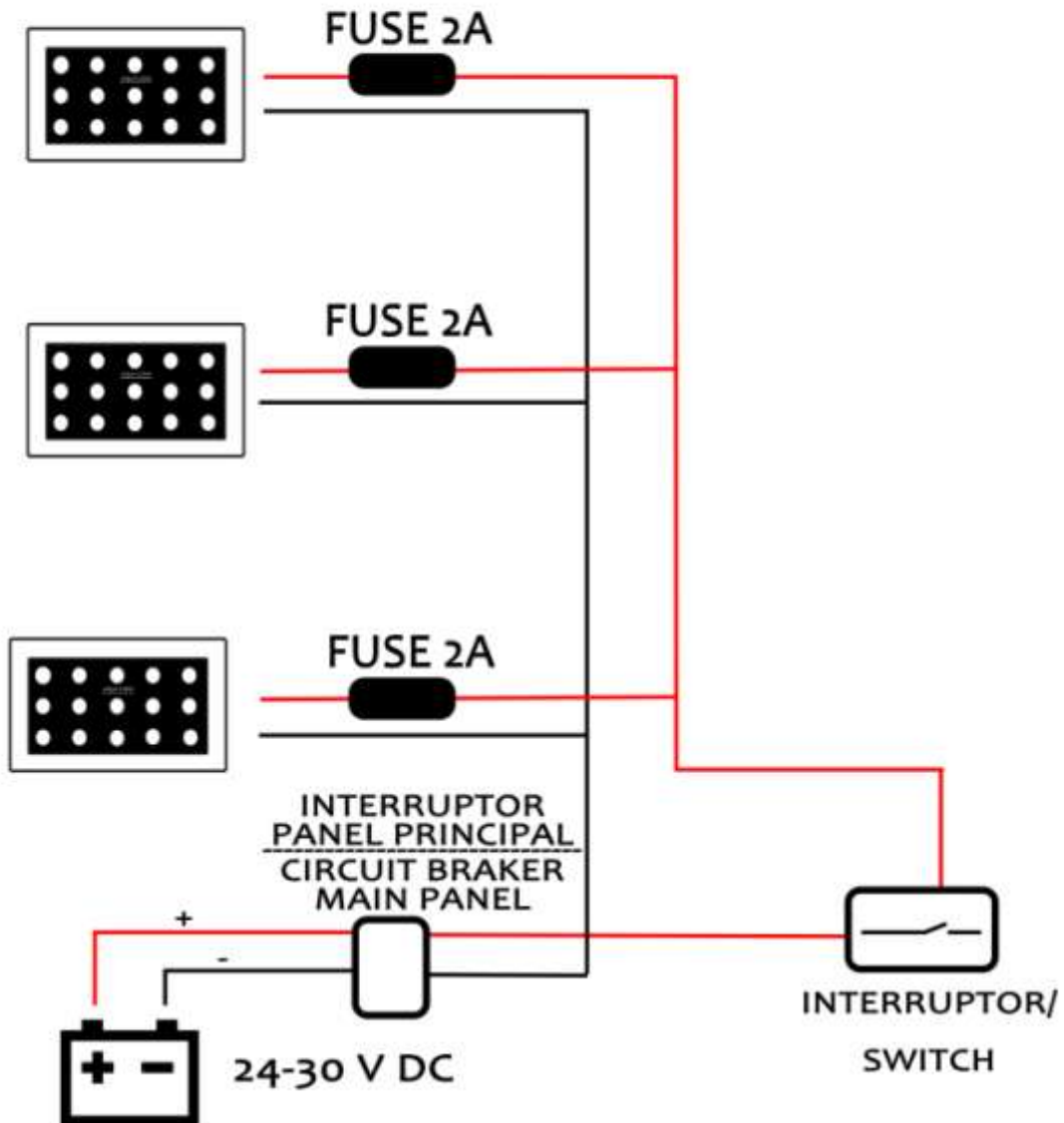

MODELO/ MODEL	1545
VOLTAJE/ VOLTAGE	20-30V DC
TEMP °K /COLOR /COLOUR	AZUL O BLANCO BLUE OR WHITE
POTENCIA / POWER	45W
CONSUMO/ CONSUMPTION	24V 0.95A
MATERIAL/ MATERIAL	INOX 316
DURACIÓN/	25000 H
ÁNGULO/ OPEN ANGLE	60º
MONTAJE/ MOUNT.	SURFACE MOUNT MONTAJE EN SUPERFICIE
Ø PERFORACIÓN Ø DRILL HOLE	10 mm- 0.39 INCHES
REGULABLE/ DIMMABLE	SI – YES
PROTECCIÓN CONTRA INVERSIÓN DE CORRIENTE PROTECTION AGAINST INVERSION CURRENT	

ESQUEMA ELÉCTRICO ELECTRICAL SCHEME



AQUA LUXES

